

# INSTALLATION SHEET - F150 Super Crew

## TUFF TONNO™

**extang**  
AMERICA'S BEST  
SELLING TONNEAUS

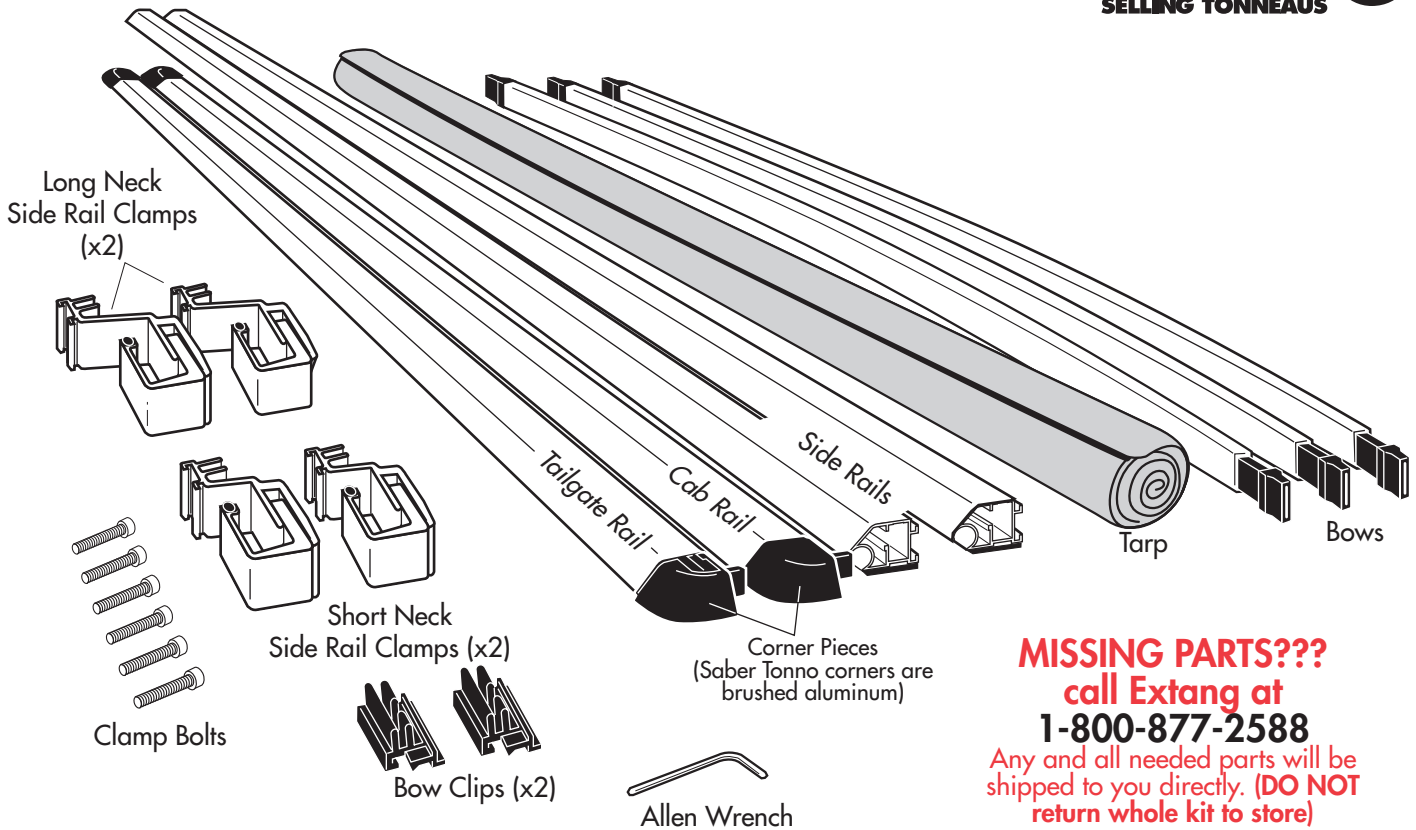

**MISSING PARTS???**  
call Extang at  
**1-800-877-2588**

Any and all needed parts will be shipped to you directly. (DO NOT return whole kit to store)

PARTS INCLUDED IN YOUR KIT. You may want to lay them out in this manner for accessibility.

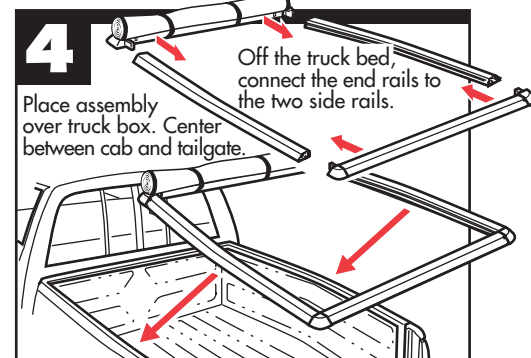
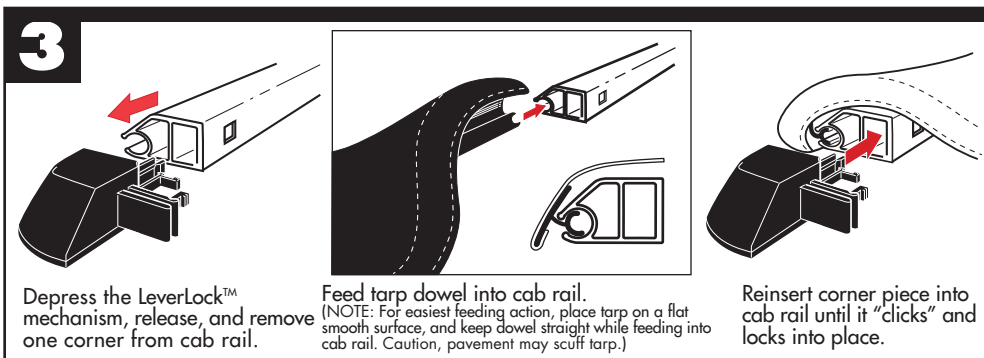

Extang Corporation  
1901 E. Ellsworth Rd.  
Ann Arbor, MI 48108  
734 677-0444, Fax: 734 677-8409

Register your warranty at:  
**www.extang.com**

Item No. 0002-0708RH Printed in U.S.A.

5

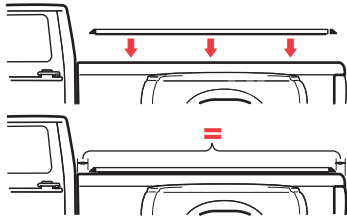

Place the rail assembly over the side of the truck box. Center rails evenly between cab and tailgate. (NOTE: Some applications have hard rubber risers (square rubber pad.) A riser must go toward tailgate. Some applications will have a riser at both ends, (most have no riser).

6

**Side Rail Clamp Spacing (Same for each side)**

See the stickers located on each side rail for clamp position, or refer to the dimensions given below. Note: Remove stickers after installation.

Place Clamp Here  
STICKER

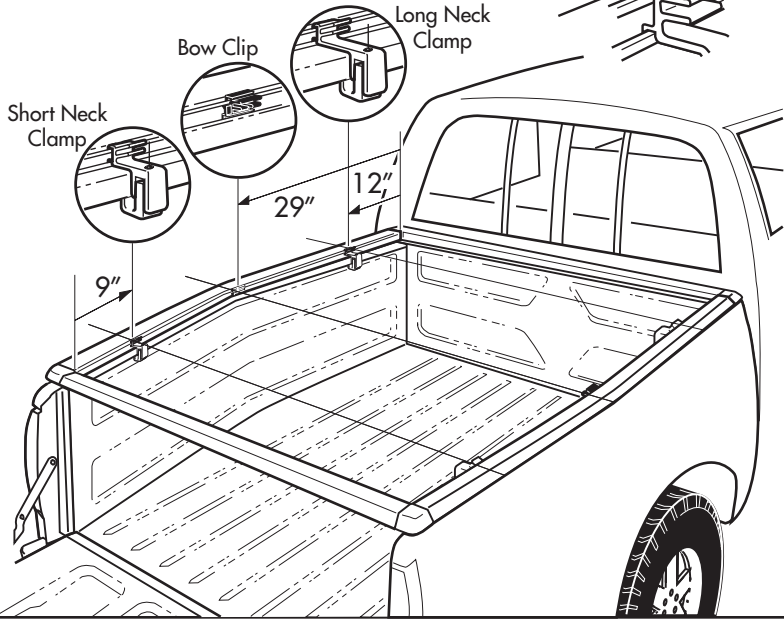

Insert side rail clamp all the way into rail.

For an OVER-THE-RAIL Bedliner



For each clamp mark on your bedliner a 1-1/2" x 3" hole as shown above. Cut holes in bedliner.

7

STANDARD CLAMP

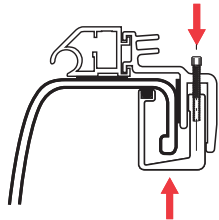

Attach "U" clamp to side rail clamp with allen bolt. Insert side rail clamp all the way into rail.

8

Insert bow onto top or bottom peg. (Top peg for performance, Bottom for good looks.)

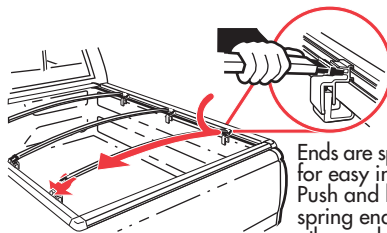

Ends are spring loaded for easy installation. Push and hold on spring end and let the other end slide on with the spring action.



SPECIAL FEATURE: Two pegs offer two height adjustments.



Do Not Place Between the Pegs

9

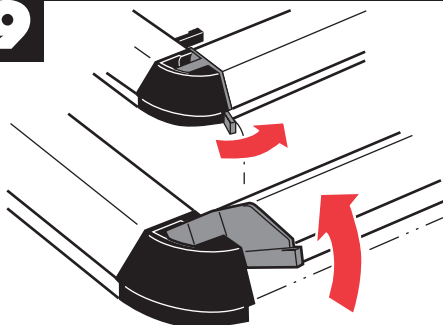

A. Release lever on both corners of tailgate rail and tilt rail up.

B. Attach tarp at front by pressing down on edge of tarp with the palms of your hands (about only 12 inches on each side). Then hook tarp to the tails rail's groove and click down to tighten tarp. See close-up.

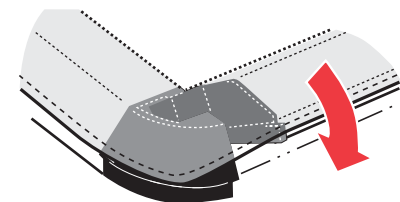
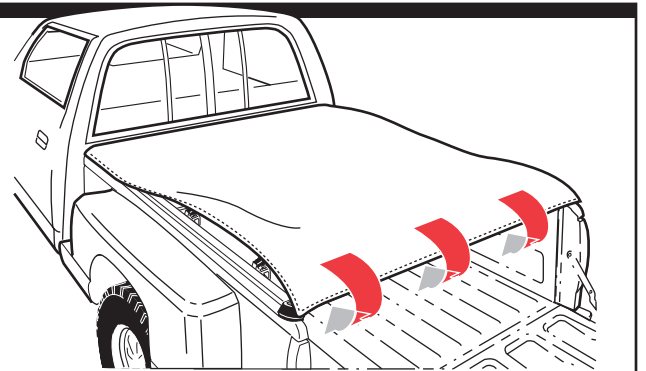

C. Close-up of downward rotation of rear rail. You will feel the "snap" effect and see it tighten snugly.

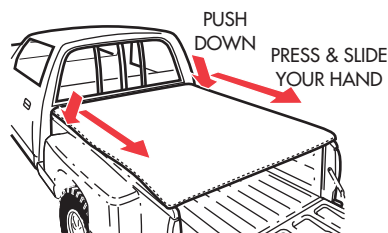

D. Finish attaching tarp along each side by pushing down and sliding your hand towards each corner. You can feel the "grip" action.

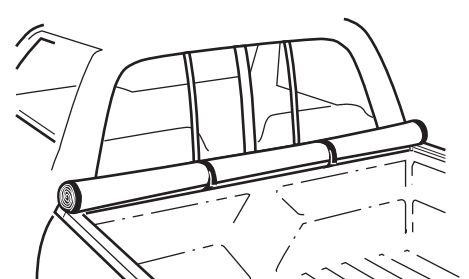

**EASY USE OF TRUCK BED**

Tarp may be rolled up and secured with Velcro® for bulk hauling