

# INSTALLATION SHEET - Explorer Sport Trac

## TUFF TONNO™

**extang**  
AMERICA'S BEST  
SELLING TONNEAUS

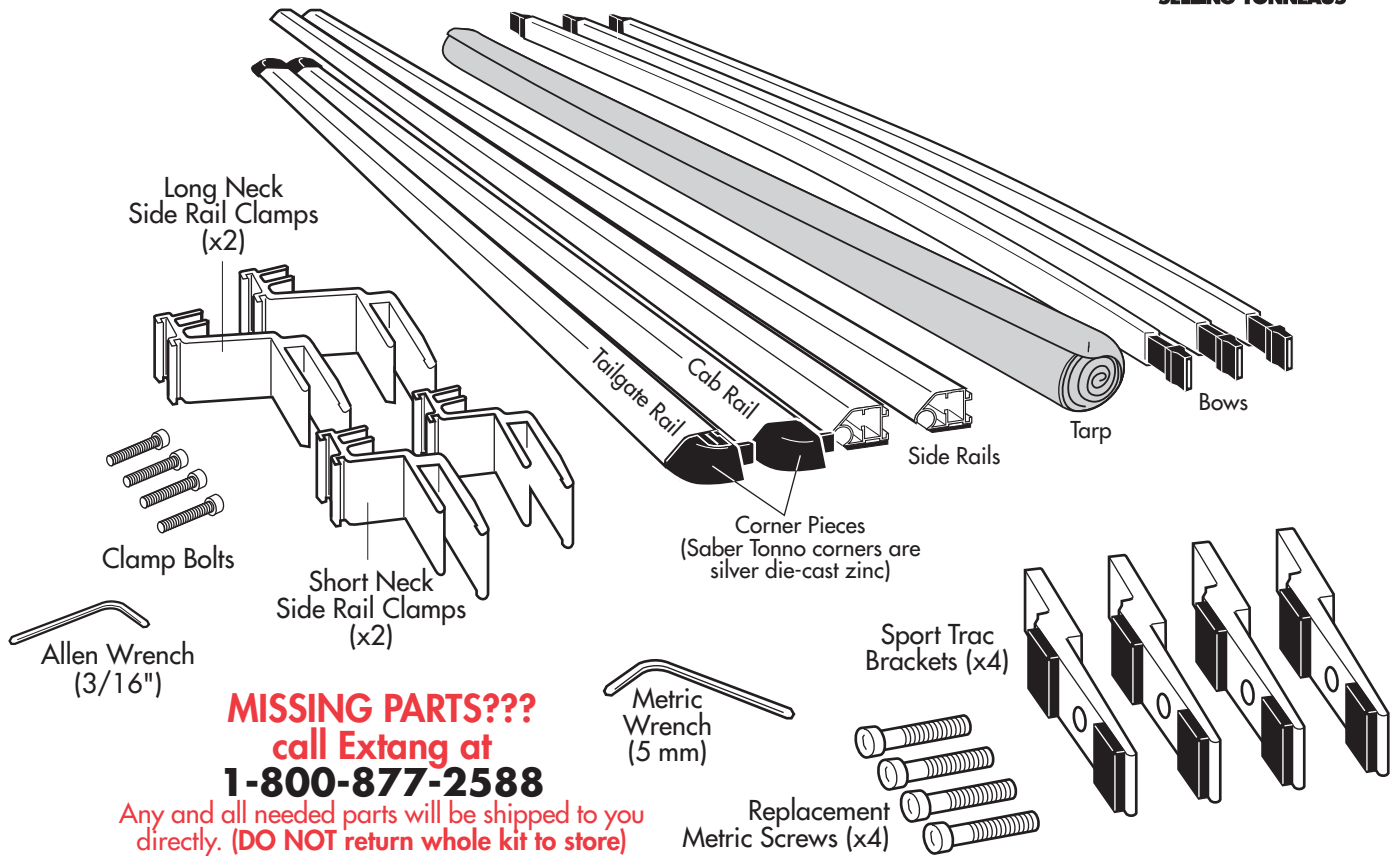

**MISSING PARTS???**  
call Extang at  
**1-800-877-2588**

Any and all needed parts will be shipped to you directly. (DO NOT return whole kit to store)

PARTS INCLUDED IN YOUR KIT. You may want to lay them out in this manner for accessibility.

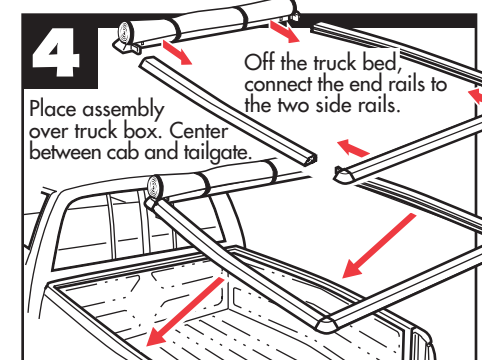
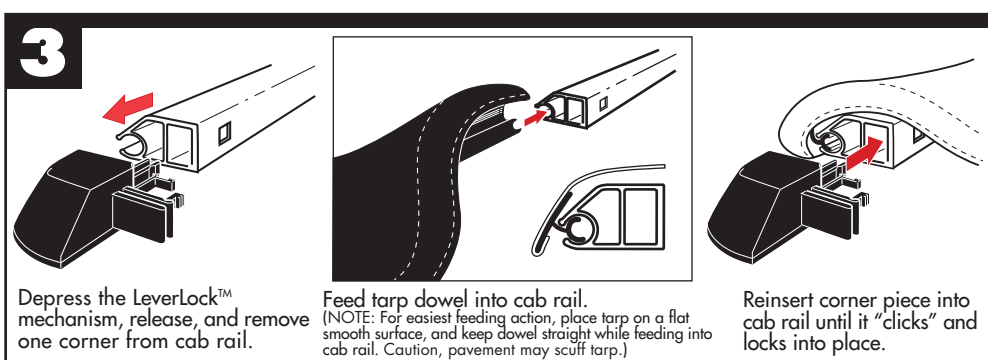

Extang Corporation  
1901 E. Ellsworth Rd.  
Ann Arbor, MI 48108  
734 677-0444, Fax: 734 677-8409

Register your warranty at:  
**www.extang.com**  
Item No. 0005-0708 RH Printed in U.S.A.

5

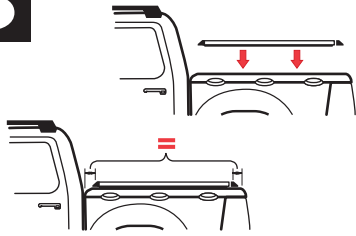

Place the rail assembly over the side of the truck box. Center rails evenly between cab and tailgate.

6

### Side Rail Clamping (Same for each side)

Remove two hex socket screws from the inside of the Sport Trac payload bed. Place Sport Trac Bracket over screw hole and replace with provided metric screws and secure firmly into bed wall with metric wrench.

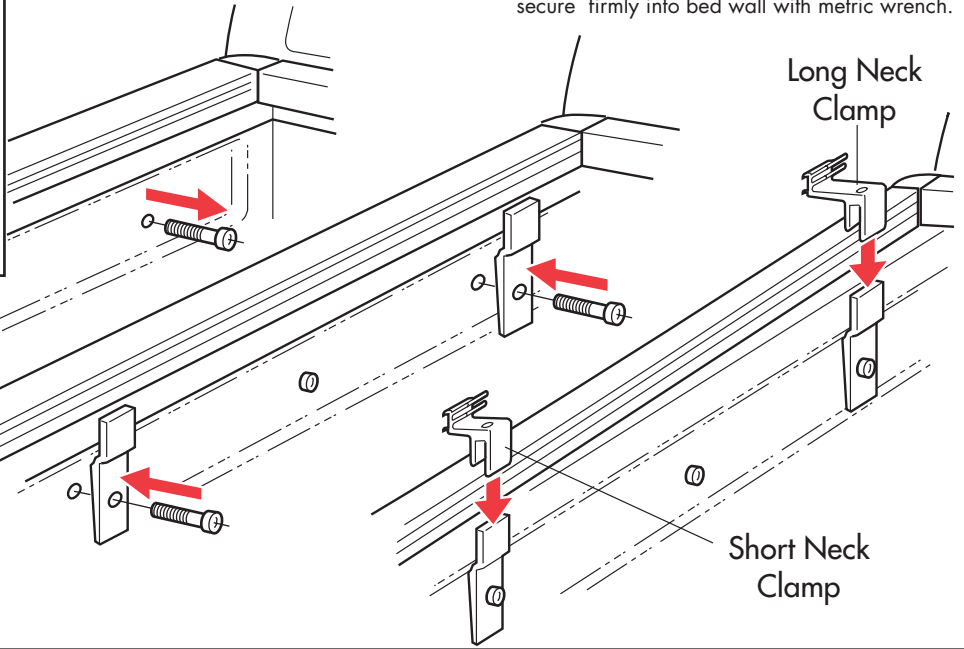

**Note:** Insert side rail clamp all the way into rail.

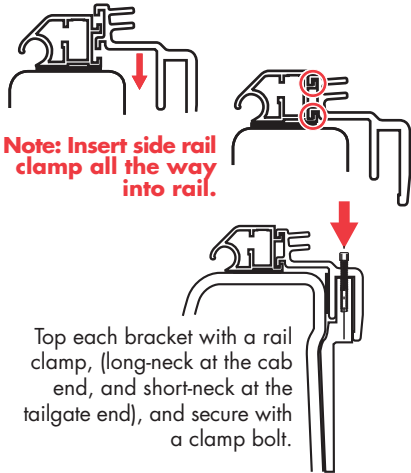

Top each bracket with a rail clamp, (long-neck at the cab end, and short-neck at the tailgate end), and secure with a clamp bolt.

7

Insert bow onto top or bottom peg.  
(Top peg for performance, Bottom for good looks.)

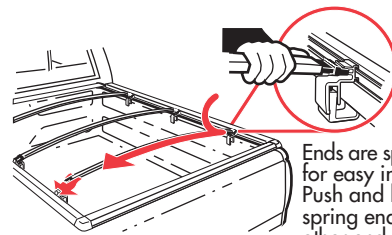

Ends are spring loaded for easy installation. Push and hold on spring end and let the other end slide on with the spring action.

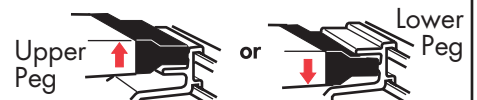

**SPECIAL FEATURE:**  
Two pegs offer two height adjustments.



**Do Not Place Between the Pegs**

**Note:**  
Bow End does not fit between pegs.

8

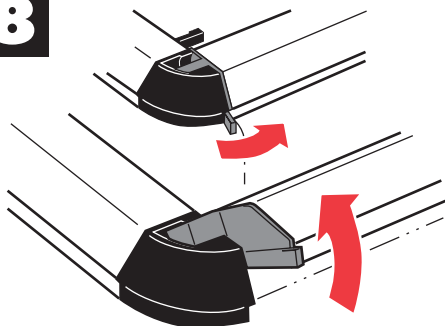

A. Release lever on both corners of tailgate rail and tilt rail up.

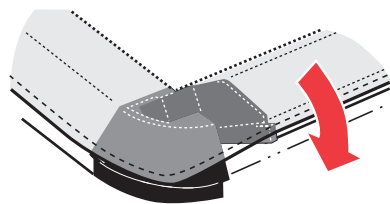

C. Close-up of downward rotation of rear rail. You will feel the "snap" effect and see it tighten snugly.

B. Attach tarp at front by pressing down on edge of tarp with the palms of your hands (about only 12 inches on each side). Then hook tarp to the tails rail's groove and click down to tighten tarp. See close-up.

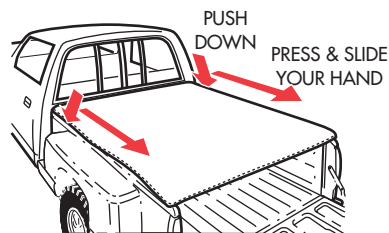
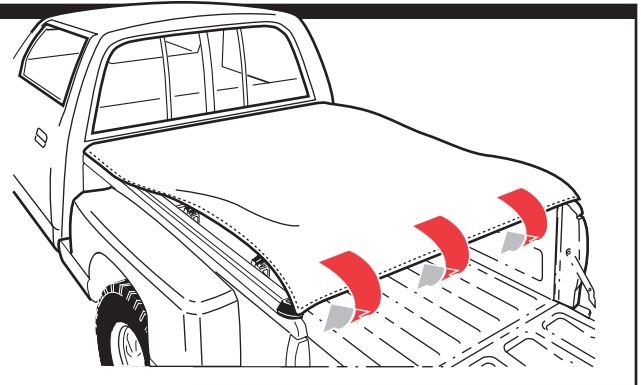

D. Finish attaching tarp along each side by pushing down and sliding your hand towards each corner. You can feel the "grip" action.

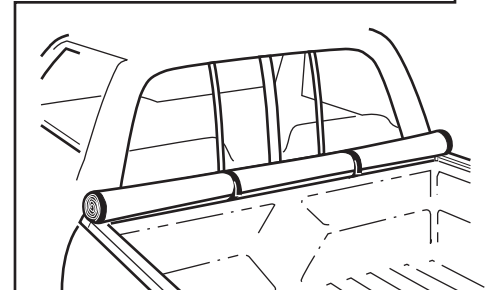

### EASY USE OF TRUCK BED

Tarp may be rolled up and secured with Velcro® for bulk hauling