

INSTALLATION SHEET

EXTANGRT TONNO



Tarp Assembly with Cab Rail, Tail Rail and support Bows attached.

Rail Clamp Assemblies with tie downs (x 4)

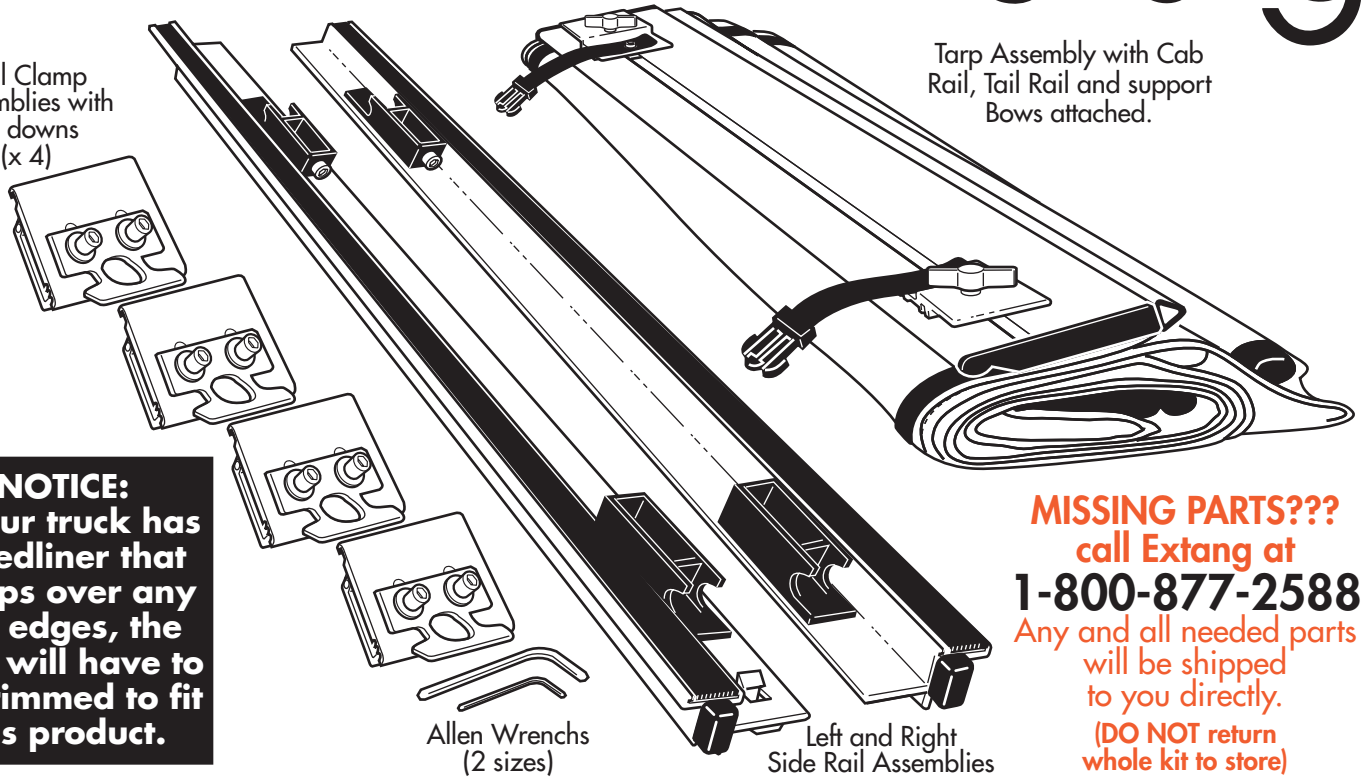

NOTICE:
If your truck has a bedliner that wraps over any top edges, the liner will have to be trimmed to fit this product.

Allen Wrenches (2 sizes)

Left and Right Side Rail Assemblies

MISSING PARTS???
call Extang at
1-800-877-2588
Any and all needed parts will be shipped to you directly.
(DO NOT return whole kit to store)

PARTS INCLUDED IN YOUR KIT. You may want to lay them out in this manner for accessibility.

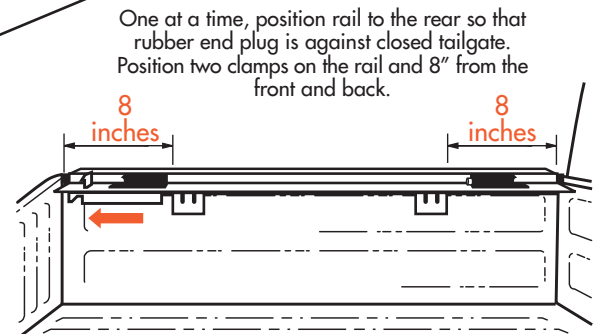
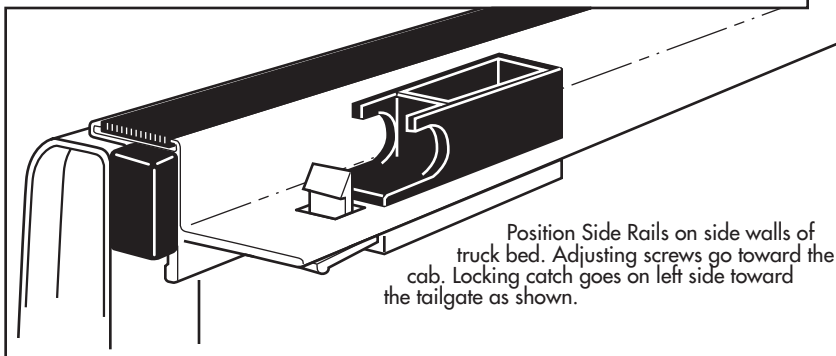
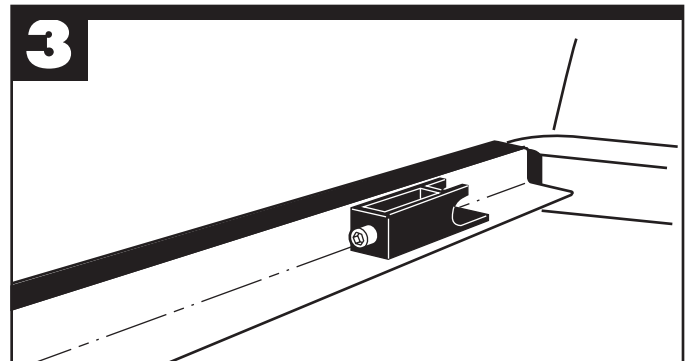
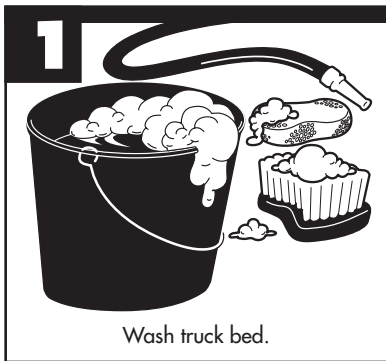

extang
Stands for Quality

Extang Corporation
1901 E. Ellsworth Rd.
Ann Arbor, MI 48108
734 677-0444, Fax: 734 677-8409

Visit us at:
www.extang.com

Item No. 0042-0904RH Printed in U.S.A.

4 If necessary, add one rail shim behind each clamp (4, total).

(Note: On some vehicles, the down-standing box flange has a sloping surface; with these vehicles it may be necessary to move inner clamp up and down and to shim rail so that rail is flat.)

Insert Pre-assembled clamp into the side rail.

Hook slot of flat clamp into lip in side rail.

Raise C-shaped inner clamp to highest position.

Hand-tighten clamp bolts to hold rail in place.

Tighten bolts with large Allen wrench. Repeat steps 3 and 4 for the other rail.

5

Engage the round edge of the cab rail to the spring blocks and rotate the rail down.

Slide the retaining plates out so that they engage the wide flange of the side rail and secure the thumbscrews to tighten.

6

Unroll your tarp from the cab rail to the tailgate. The tonno bows are deployed as the tarp is unrolled.

If needed, you can adjust the alignment of the tailgate rail by changing the tailgate strap positions.

7

Engage the tailgate block and rotate it down to the spring catch.

Note: Cab and tailgate seal may be trimmed to fit.

To adjust the tension of the tarp, rotate the screw using the large Allen Wrench.

Push up on spring tab to release tonno catch and roll the tonno forward.

8

Seal the tonno by pressing the velcro® fastening strips from the cab end and press all the way back.

Before using any commercial car wash, push down both sides of the Velcro® strips. This will reduce the possibility of water entering the truck bed.

Over time, the velcro might develop a fuzzy appearance. This is normal and will increase the holding strength.

For care instructions see tag on underside of tarp

EASY USE OF TRUCK BED

Tarp may be rolled up and secured with buckle straps for bulk hauling. For more access, tarp can also be removed completely by loosening T-knobs.

Built in Tie-downs

Clamp tie-downs for light to moderate loads (100 lbs max.) can be used whether tonno is in place or not.

Light Loads (under 100 lbs.)

WARRANTY INSTRUCTIONS

EXTANGRT
TONNO



For Warranty Service on your ExtangRT Tarp, you must remove the two end-bars and all support bows. See instructions below for removal of these hardware fixtures. For your reference the part number for the RT Tarp is 26xxx•.

SHIP ONLY THE TARP FOR WARRANTY SERVICE.

NOTE: The xxx represents the 3-digit application number (vehicle type) following the 1- or 2-digit prefix, as referenced on the vehicle application list or sales receipt.

Call our Customer Service Department at 1-800-877-2588 for assistance.

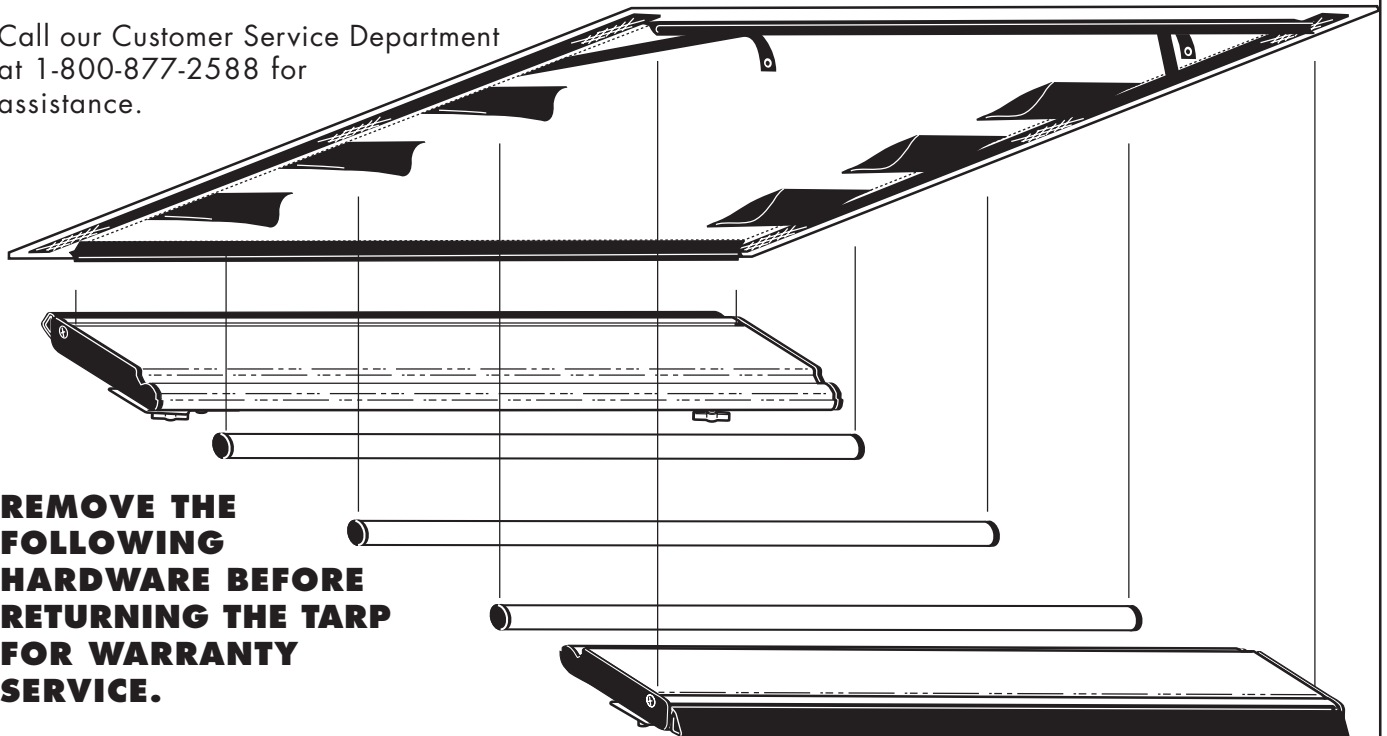

REMOVE THE FOLLOWING HARDWARE BEFORE RETURNING THE TARP FOR WARRANTY SERVICE.

To disconnect the Tarp from the Cab and Tailgate Bars remove the retaining screw from one end cap and slide the bar off of the Tarp's plastic channel.

NOTE: On some models the screw is located within the rounded channel of the bar.

Remove the support bows by extracting them from the fabric pockets in the underside of the Tarp.

NOTE: Ship only Tarp for warranty service.

IMPORTANT For Reassembly:

- Attach the Tail Bar to the "Tag-end" of the replacement Tarp.
- Reinstall the support bows, longest at Cab end and shortest at Tailgate end (or as labeled).
- Replace end-caps and screws making sure each rail is centered with the tarp.

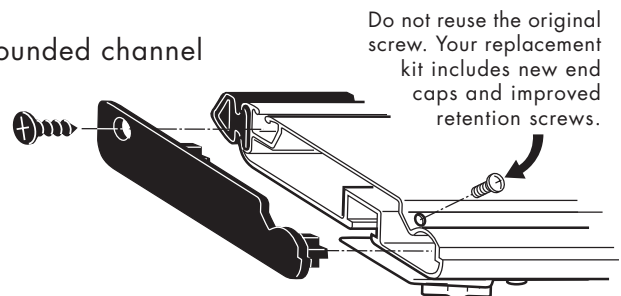

extang
stands for quality

Extang Corporation, 1901 E. Ellsworth Rd., Ann Arbor, MI 48108, 734 677-0444, Fax: 734 677-8409, Visit us at: www.extang.com

Item No. 0136-0604RH Printed in U.S.A.