

# INSTALLATION SHEET Ford Flareside

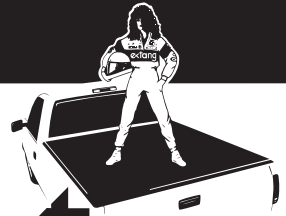

# EXTANG RT TONNO

# extang

Rail Clamp Assemblies with 3 Screws (x 4)

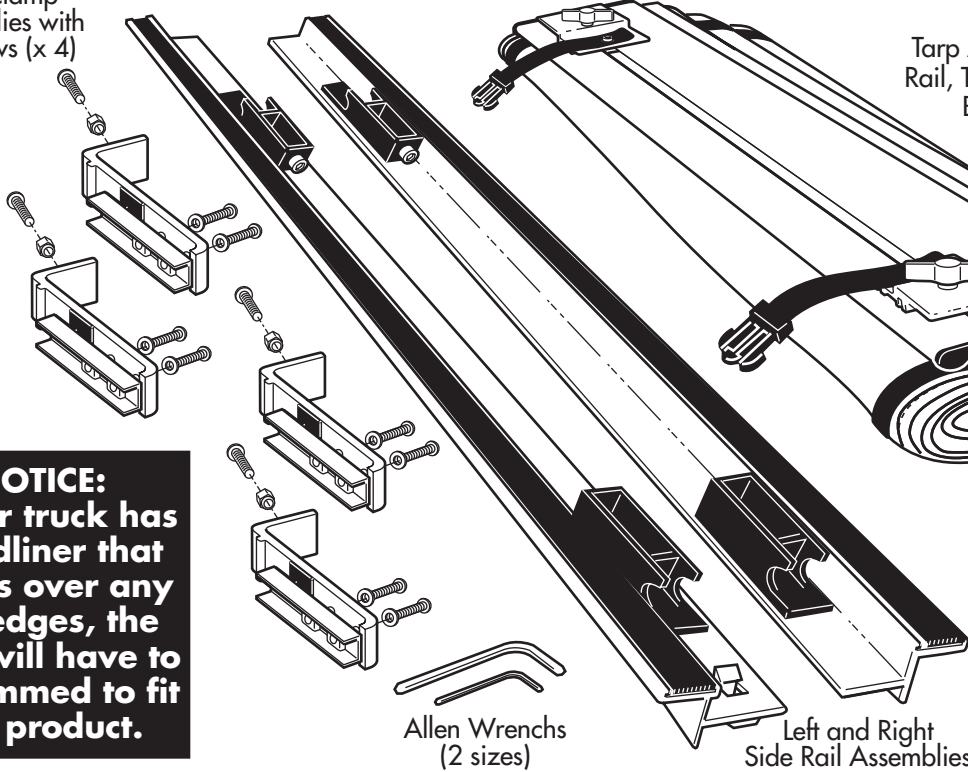

Tarp Assembly with Cab Rail, Tail Rail and support Bows attached.

**NOTICE:**  
If your truck has a bedliner that wraps over any top edges, the liner will have to be trimmed to fit this product.

**MISSING PARTS???**  
call Extang at  
**1-800-877-2588**  
Any and all needed parts will be shipped to you directly.  
**(DO NOT return whole kit to store)**

**PARTS INCLUDED IN YOUR KIT.** You may want to lay them out in this manner for accessibility.

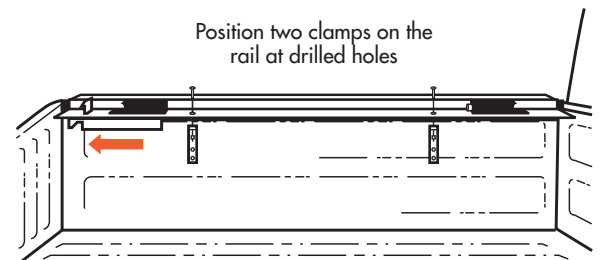
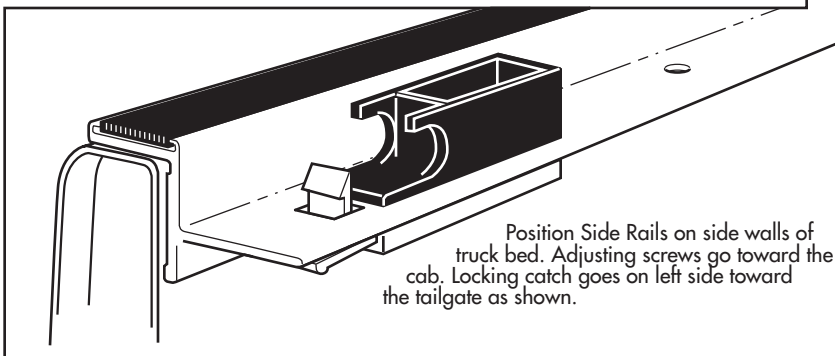
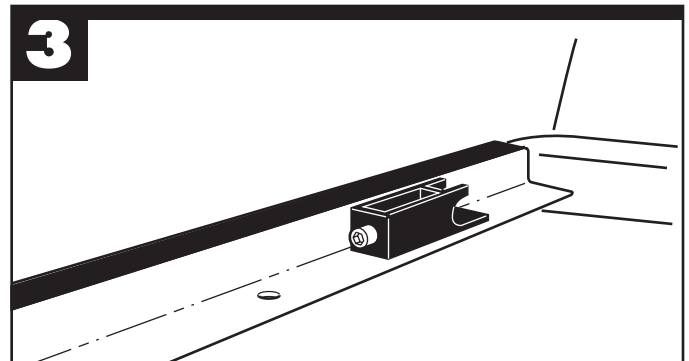

**extang**  
Stands for Quality

Extang Corporation  
1901 E. Ellsworth Rd.  
Ann Arbor, MI 48108  
734 677-0444, Fax: 734 677-8409

Visit us at:  
**www.extang.com**

Item No. 0141-0904RH Printed in U.S.A.

**4**

Attach Pre-assembled clamp onto the side rail.

Hand-tighten all three clamp bolts to hold rail in place.

Tighten bolts with small Allen wrench. Repeat steps 3 and 4 for the other rail.

**5**

Engage the round edge of the cab rail to the spring blocks and rotate the rail down.

Slide the retaining plates out so that they engage the wide flange of the side rail and secure the thumbscrews to tighten.

**6**

Unroll your tarp from the cab rail to the tailgate. The tonno bows are deployed as the tarp is unrolled.

If needed, you can adjust the alignment of the tailgate rail by changing the tailgate strap positions.

**7**

Engage the tailgate block and rotate it down to the spring catch.

**Note: Cab and tailgate seal may be trimmed to fit.**

Push up on spring tab to release tonno catch and roll the tonno forward.

To adjust the tension of the tarp, rotate the screw using the large Allen Wrench.

**8**

Seal the tonno by pressing the velcro fastening strips from the cab end and press all the way back.

Before using any commercial car wash, push down both sides of the Velcro strips. This will reduce the possibility of water entering the truck bed.

**For care instructions see tag on underside of tarp**

**EASY USE OF TRUCK BED**

Tarp may be rolled up and secured with buckle straps for bulk hauling. For more access, tarp can also be removed completely by loosening T-knobs.

Over time, the velcro might develop a fuzzy appearance. This is normal and will increase the holding strength.