

INSTALLATION SHEET

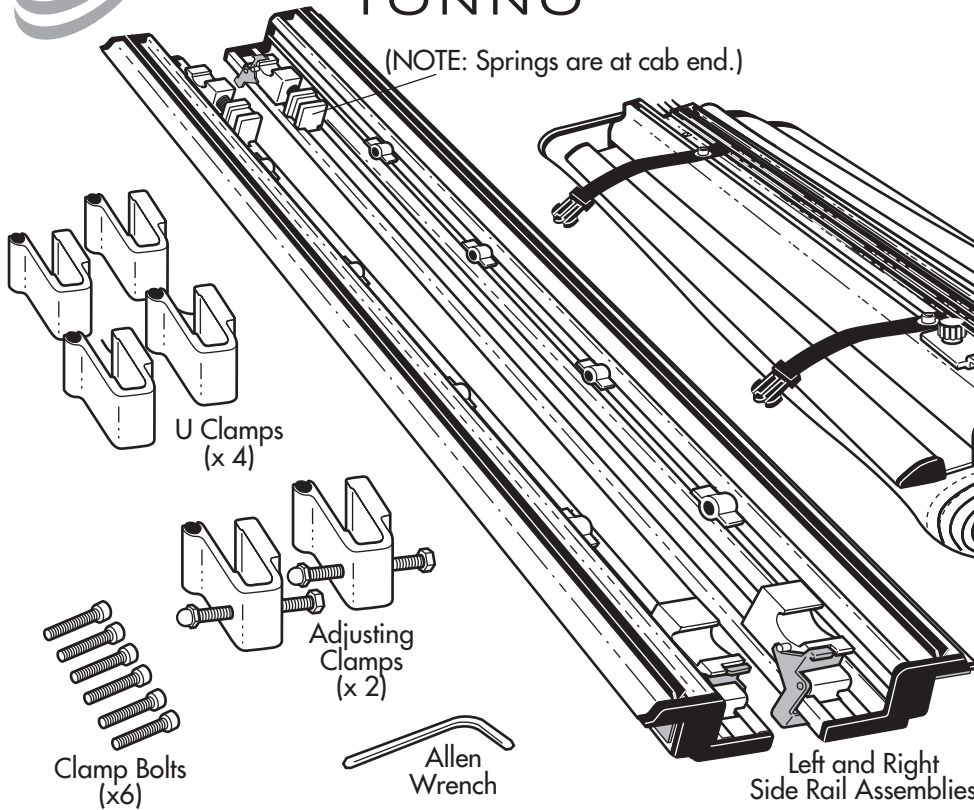

Tarp Assembly with Cab Rail, Tail Rail and Support Bows attached.

MISSING PARTS???
 call Extang at
1-800-877-2588
 Any and all needed parts
 will be shipped
 to you directly.
(DO NOT return whole kit to store)

PARTS INCLUDED IN YOUR KIT. You may want to lay them out in this manner for accessibility.

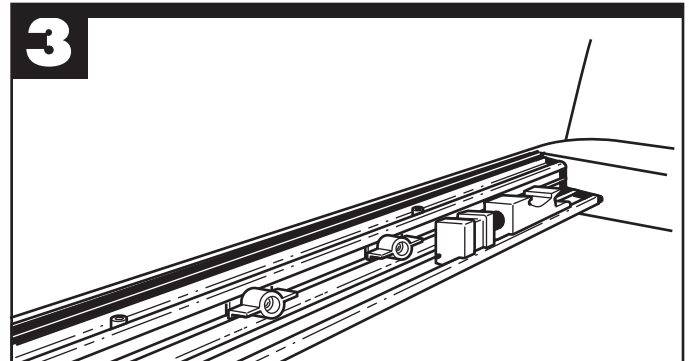
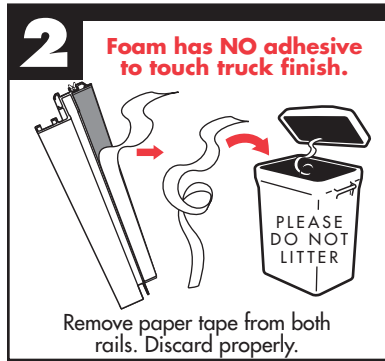
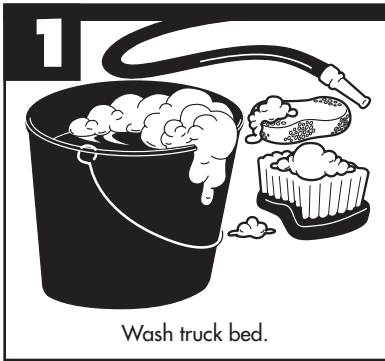

4

With rail positioned, locate the predrilled holes on the rail for U-Clamps and Adjusting Clamps.

Insert clamps and loosely attach bolts.

Push rail downward and outward and tighten bolts with Allen wrench provided. Repeat steps 3 and 4 for the other rail.

Rear clamp is adjustable to keep tail end of side rail square to bed. Use shortest bolt that engages sidewall.

Use the most outboard position that the clamp will fit.

5

Place tonno assembly in the cab end of truck bed.

Pull back into groove and rotate down

Prior to driving vehicle make sure the slide lock at cab rail is secure.

Engage the narrow edge of cab rail against the pivot block. **NOTE:** Rail will not engage if slide blocks are too far outside the tie straps or are under the rail.

Slide the slide block outward so that it engages the wide flange of the side rail. Secure the knurled knobs to tighten. **IF NEEDED, PUSH DOWN ON CAB RAIL TO MOVE SLIDE**

6

Unroll your tarp from the cab rail to the tailgate. The tonno bows are deployed as the tarp is unrolled.

Be sure that the bow-ends engage the bow catchers attached to the side rails. It may be necessary to loosen a bow catcher and slide it to engage the bow-end when the rear rail is locked. **The bow catchers can be adjusted using the Allen wrench provided.**

Bow Catcher

If needed, you can adjust the alignment of the tailgate rail by changing the tailgate strap positions.

7

Insert tail rail into the tailgate block and rotate it down to the spring lever. Tarp is self-tensioning.

Keep tension on the tarp to be sure that last bow stays connected to the catcher.

Push down here to keep pressure on the last bow.

The last bow needs to engage the catcher.

To release tarp, pull forward on right and left spring levers.

Make sure spring-loaded bow ends and rail ends are inserted into the open flaps of the tarp. Bow springs can be retracted to reinsert into the fabric layer.

EASY USE OF TRUCK BED

Tarp may be rolled up and secured with buckle straps for bulk hauling. For more access, tarp can also be removed completely by loosening knurled knobs, retracting slide blocks and pulling the forward catch lever down.